

S.C. ULTRA PROIECT S.R.L.  
PROIECTARE DRUMURI SI PODURI  
J04/632/2008, C.I.F. RO 23585508  
Jud. Bacau, Com. Magura, Sat Magura  
Tel: 0742.351.456, Fax: 0334.107.748  
e-mail: ultra\_proiect@yahoo.com



ISO 9001  
ISO 14001  
OHSAS 18001



**PROIECT NR. 481/2024**

**PROIECT TEHNIC**

**MODERNIZARE STRADA PIETEI SI  
STRADA BURDUJENI, SAT ARINI,  
COMUNA GAICEANA, JUDETUL BACAU"**

**B. PIESE DESENATE**

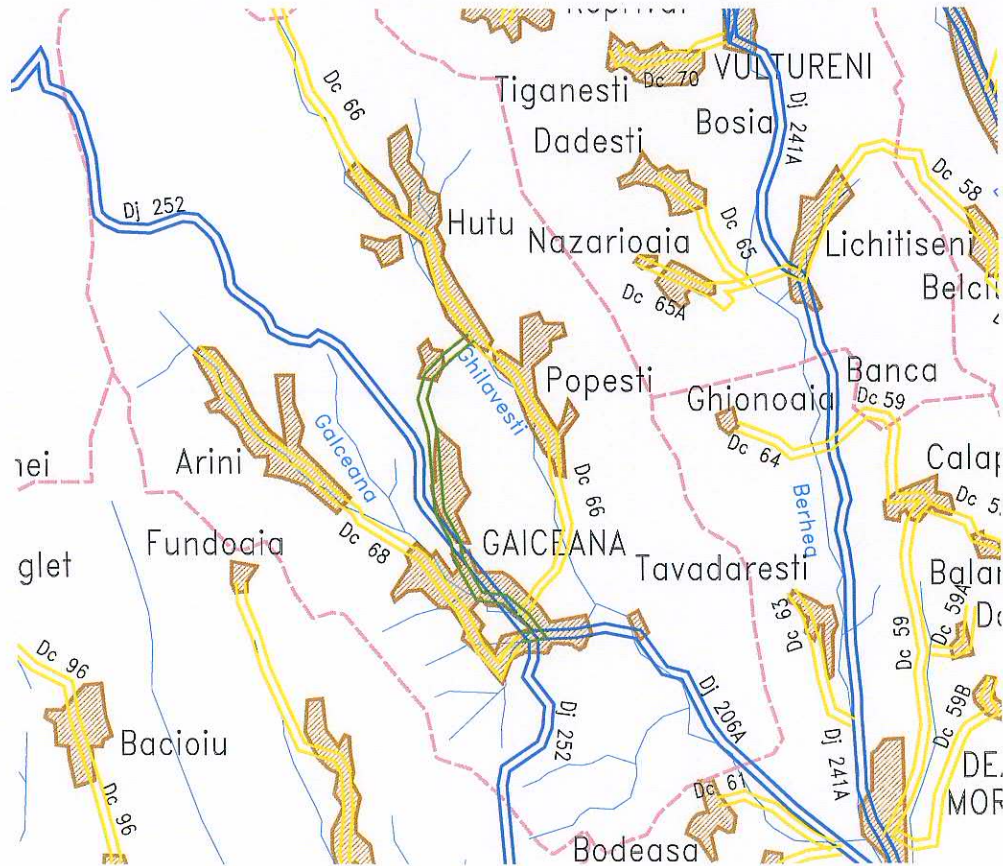

**BENEFICIAR: COMUNA GAICEANA**

**AMPLASAMENT : România, Regiunea Nord Est, Județul Bacau, Comuna Gaiceana**

**PROIECTANT GENERAL: S.C. ULTRA PROIECT S.R.L. BACAU**

**FAZA DE PROIECTARE: P.Th. – PROIECT TEHNIC**

*Exemplar nr.*

MARTIE 2024

 <p><b>PROIECTARE DRUMURI SI PODURI</b>  <b>S.C. ULTRA PROIECT S.R.L.</b>  J04/632/2008, C.I.F. RO 23585508  Jud. Bacau, Com. Magura, Sat Magura  E-mail: ultra_proiect@yahoo.com  Tel: 0742 351 456; Fax: 0334 809 819</p>	Denumire proiect: „MODERNIZARE STRADA PIETEI SI STRADA BURDUJENI, SAT ARINI, COMUNA GĂICEANA, JUDEȚUL BACĂU” Beneficiar: <b>COMUNA GĂICEANA , JUDEȚUL BACĂU</b> PROIECT nr: 481/2024 Faza : P.TH(PROIECT TEHNIC) – B - PIESE DESENATE	Piese scrise	Pag 1
---	--	--------------	----------

## BORDEROU



### Piese desenate:

- Plansa D1. Plan de încadrare în zona, Sc 1:5000;
- Plansa D2. Plan de situație, Sc 1:500;
- Plansa D3. Profil transversal tip, Sc 1:50;
- Plansa D4. Profil transversal tip, Sc 1:50;
- Plansa D5. Profil longitudinal tronson 1, Sc 1:500, 1:50;
- Plansa D6. Profil longitudinal tronson 2, Sc 1:500, 1:50;
- Plansa D7. Profile transversale tronson 1, Sc 1:100;
- Plansa D8. Profile transversale tronson 1, Sc 1:100;
- Plansa D9. Profile transversale tronson 1, Sc 1:100;
- Plansa D10. Profile transversale tronson 2, Sc 1:100;
- Plansa D11. Detaliu rigola acostament, Sc. 1:10;
- Plansa D12. Detaliu rigola carosabila, Sc. 1:10, 1:20;
- Plansa D13. Podet dalat la drum lateral H=0.4m, l=0.5m, L=8.0m, Sc. 1:20;
- Plansa D14. Plan cofraj si armare dale podet dalat H=0.4m, l=0.5m, L=8.0m, Sc. 1:10, 1:20;

Întocmit,  
ing. Dragos Contoman



PLAN DE INCADRARE IN ZONA  
SC. 1:5000

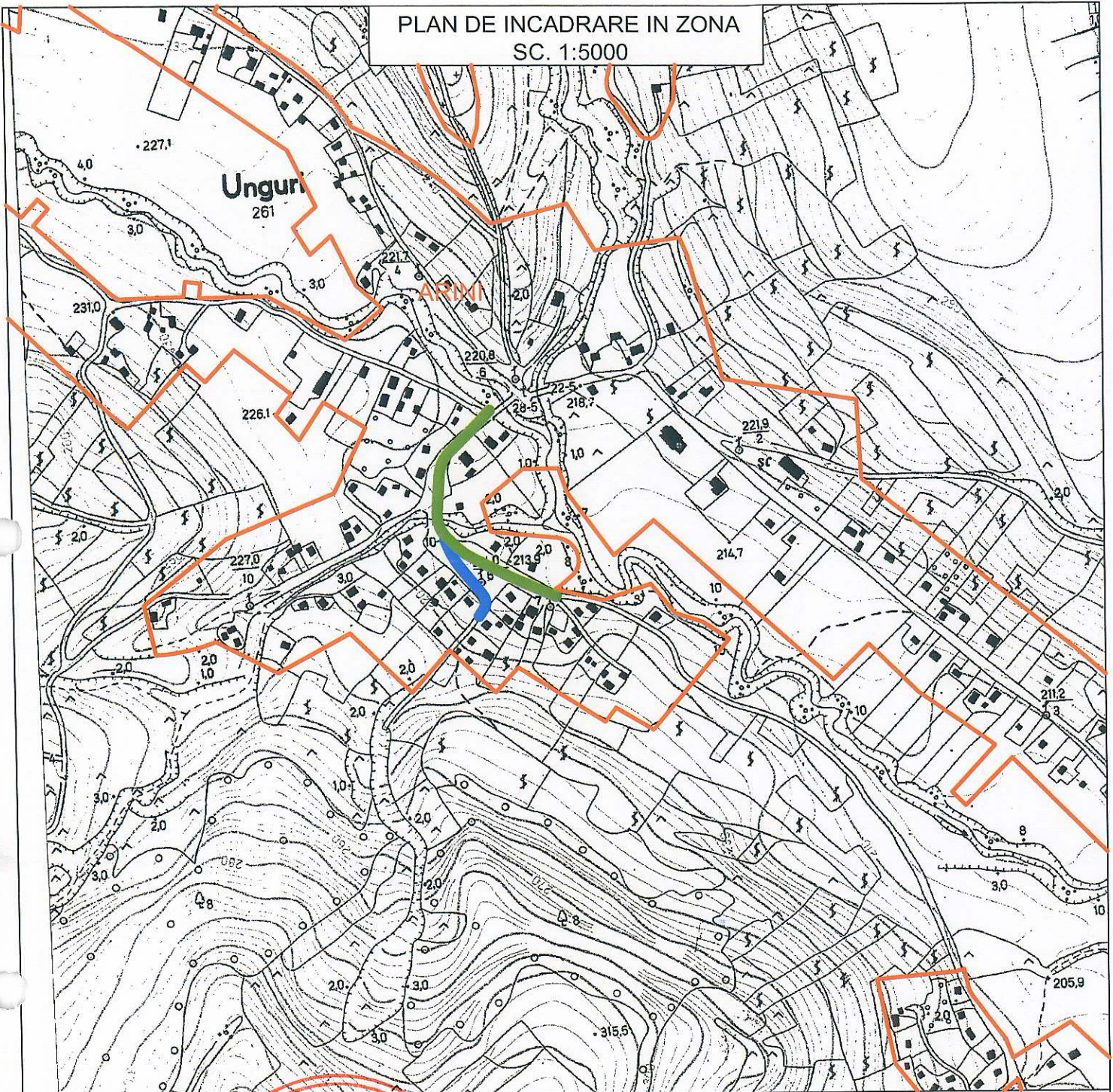

LEGENDA SI SIMBOLURI

- - LIMITA P.U.C.G.
- - STRADA PIETEI SI STRADA BURDUJENI- TRONSON 1, L=255 m
- - STRADA PIETEI SI STRADA BURDUJENI- TRONSON 2, L=85 m

SCARA DESENULUI

( IN METRI )  
1 cm pe plan -50 m pe teren



VERIFICATOR	NUME:	SEMNTURA CERINTA	REFERAT NR...../ DATA:.....
<p><b>S.C. ULTRA PROIECT S.R.L.</b> BACAU</p> <p>Sat Magura, Comuna Magura, Judetul Bacau J04/632/2008 ; C.U.I. RO 23585508 Tel/Fax :0742 351456 ; 0334.107.749;</p>		<p>BENEFICIAR: COMUNA GAICEANA AMPLASAMENT: COMUNA GAICEANA, JUDETUL BACAU</p>	
<p>PROIECT NR. 481/2024</p>		<p>Faza: P.Th.+ D.E.</p>	
SPECIFICATIE	NUME	SEMNTURA	Scara:
SEF PROIECT	ing. Dragos Contoman	<i>Dragos Contoman</i>	1:5000
DESENAT	ing. Dragos Contoman	<i>Dragos Contoman</i>	Data:
PROIECTAT	ing. Dragos Contoman	<i>Dragos Contoman</i>	03/2024
Titlu proiect:			MODERNIZARE STRADA PIETEI SI STRADA BURDUJENI, SAT ARINI, COMUNA GAICEANA, JUDETUL BACAU
Titlu plansa:			PLAN DE INCADRARE IN ZONA
			Plansa D1

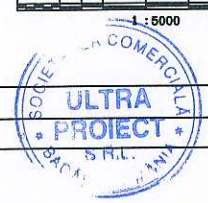

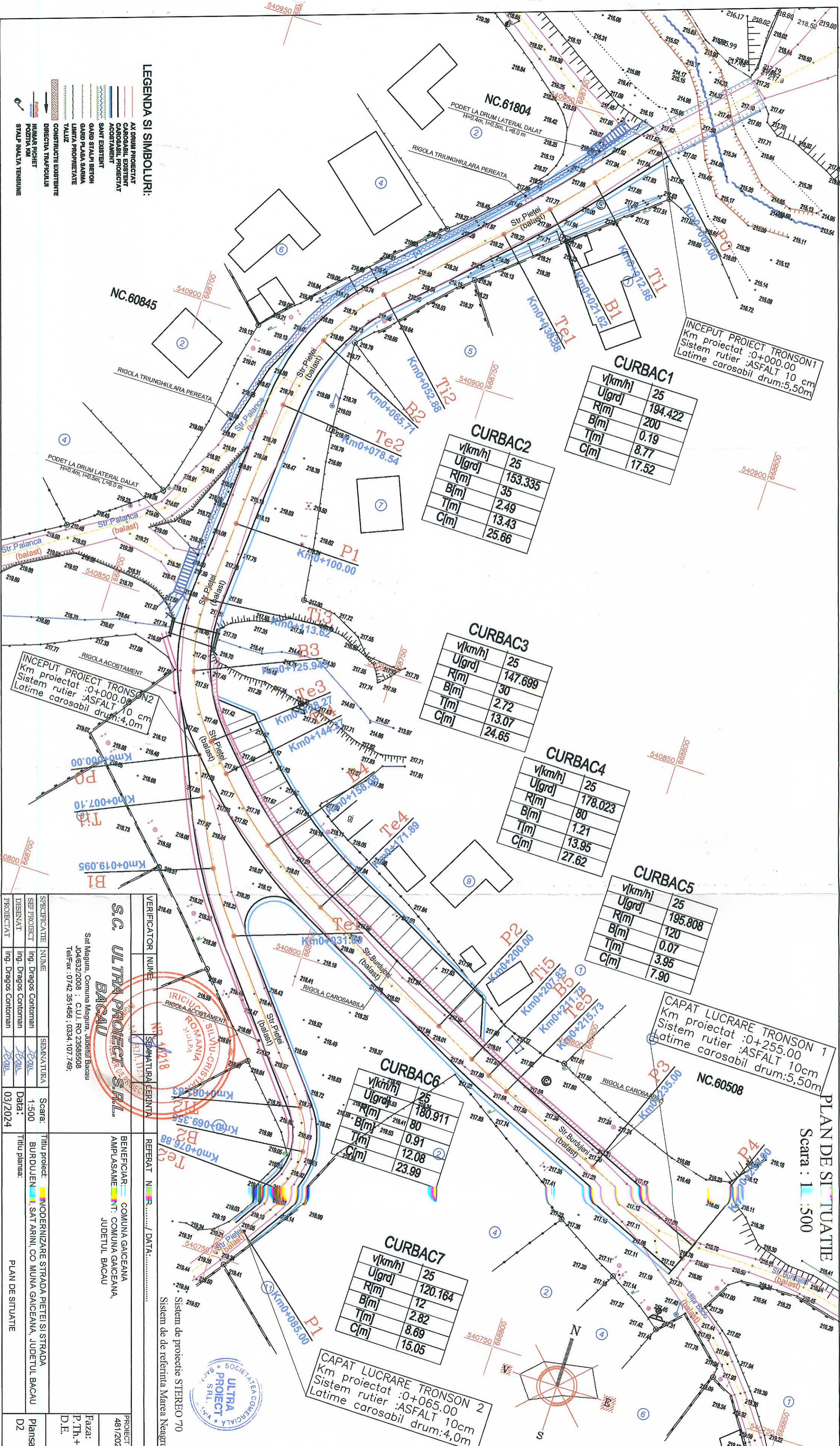

**LEGENDA SI SIMBOLURI:**

- AX DRUM PROIECTAT
- CAROSABIL EXISTENT
- CAROSABIL PROIECTAT
- ACOSTAMENT
- SAUT EXISTENT
- GARD STALPI BETON
- GARD PLASA SARMA
- LIMITA PROPRIETATE
- TALUZ
- CONSTRUCTII EXISTENTE
- DIRECTIA TRAFICULUI
- NUMAR PICHET
- POZITIA KM
- STALP INALTA TENSIUNE

INCEPUT PROIECT TRONSON 1  
Km proiectat :0+000.00  
Sistem rutier :ASFALT 10 cm  
Latime carosabil drum:5,50m

**CURBAC1**

v[km/h]	25
U[grd]	194.422
R[m]	200
B[m]	0.19
T[m]	8.77
C[m]	17.52

**CURBAC2**

v[km/h]	25
U[grd]	153.335
R[m]	35
B[m]	2.49
T[m]	13.43
C[m]	25.66

**CURBAC3**

v[km/h]	25
U[grd]	147.699
R[m]	30
B[m]	2.72
T[m]	13.07
C[m]	24.65

**CURBAC4**

v[km/h]	25
U[grd]	178.023
R[m]	80
B[m]	1.21
T[m]	13.95
C[m]	27.62

**CURBAC5**

v[km/h]	25
U[grd]	195.808
R[m]	120
B[m]	0.07
T[m]	3.95
C[m]	7.90

**CURBAC6**

v[km/h]	25
U[grd]	180.911
R[m]	80
B[m]	0.91
T[m]	12.08
C[m]	23.99

**CURBAC7**

v[km/h]	25
U[grd]	120.164
R[m]	12
B[m]	2.82
T[m]	8.69
C[m]	15.05

CAPAT LUCRARE TRONSON 1  
Km proiectat :0+255.00  
Sistem rutier :ASFALT 10cm  
Latime carosabil drum:5,50m

CAPAT LUCRARE TRONSON 2  
Km proiectat :0+065.00  
Sistem rutier :ASFALT 10cm  
Latime carosabil drum:4,0m

**S.C. ULTRA PROJECT S.R.L.**  
BACAU

Sai Magura, Comuna Magura, Judetul Bacau  
 Tel: 0742 351456; 0334 107 749;  
 C.U.I. RO 23585508  
 J404632/2008

VERIFICATOR	NUME	SEMANATURA	DATA
VERIFICATOR	NUME	SEMANATURA	DATA

REPERAT N. .... / DATA: .....

BENEFICIAR: COMUNA GAICENEA  
AMPLASAM: NT. COMUNA GAICENEA, JUDETLUL BACAU

PROIECT NR 481/2024

Faza: P.T.H.+ D.E.

Titlu proiect: MODERNIZARE STRADA PIETEI SI STRADA BURDUJEN SAT ARINI, COMUNA GAICENEA, JUDETLUL BACAU

Titlu planşa: PLAN DE SITUATIE

PLAN DE SITUATIE

PLAN DE SITUATIE  
Scara : 1 : 500



### PROFIL TRANSVERSAL TIP 1

Se aplica pe tronson 1 de la Km 0+000.00 - Km 0+120.00

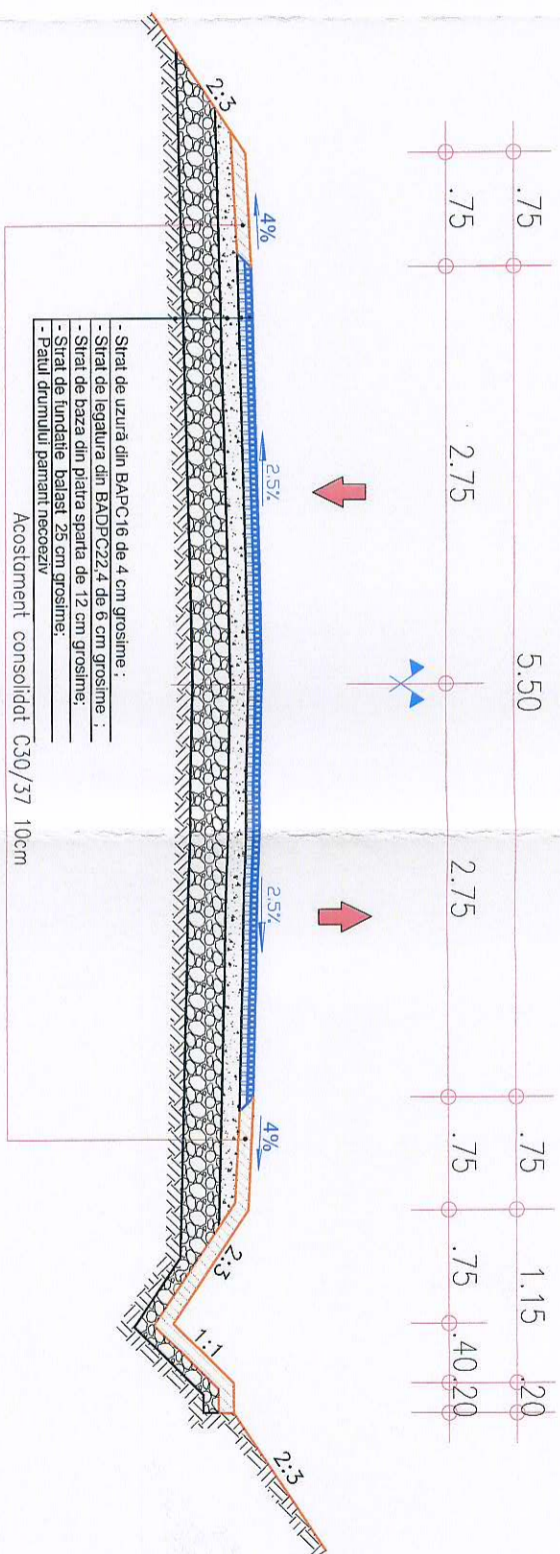

### PROFIL TRANSVERSAL TIP 2

Se aplica pe tronson 1 de la Km 0+120.00 - Km 0+130.00  
si de la Km 0+207.00 - Km 0+255.00

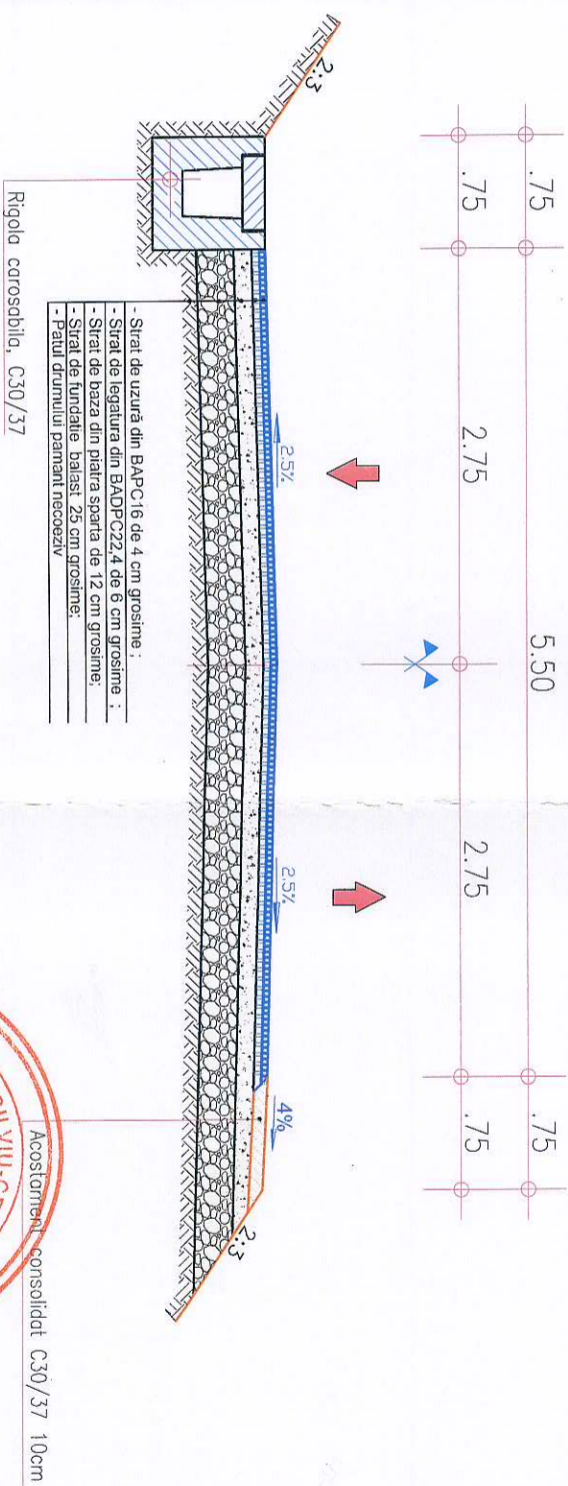

VERIFICATOR	NUME:	SEMNATURA	CERINTA	REFERAT NR...../DATA.....	PROIECT NR
		<i>[Signature]</i>			4811/2024
<b>S.C. ULTRA PROJECT S.R.L.</b> BACAU Sat Magura, Comuna Magura-Judetul Bacau J04/632/2008 ; C.U.I. RO 23585508 Tel/fax : 0742 351456 ; 0334.107.749.				BENEFICIAR: COMUNA GAICEANA AMPPLASAMENT: COMUNA GAICEANA, JUDETUL BACAU	
SPECIFICATIE	NUME	SEMNATURA	SCARA:	TITLU PROIECT:	Faza:
SEM PROIECT	Ing. Dragos Contoman	<i>[Signature]</i>	1:50	MODERNIZARE STRADA PIETEI SI STRADA BURDUJENI, SAT ARINI, COMUNA GAICEANA, JUDETUL BACAU	P.Th.+ D.E.
DESIGNAT	Ing. Dragos Contoman	<i>[Signature]</i>	Data:	TITLU PLANSA:	
PROIECTAT	Ing. Dragos Contoman	<i>[Signature]</i>	03/2024	PROFIL TRANSVERSAL TIP	Plansa D3

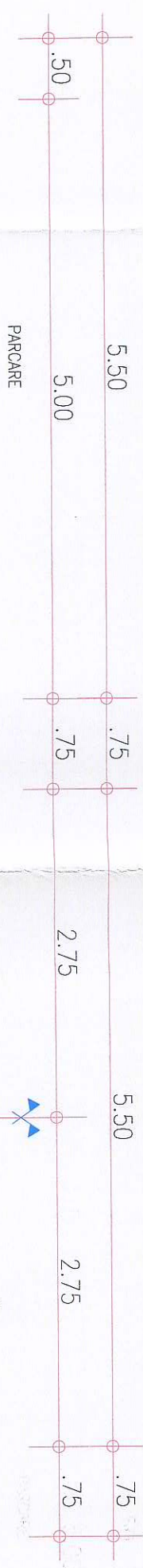

PROFIL TRANSVERSAL TIP 3  
Se aplica pe tronson 1 de la Km 0+130.00 - Km 0+207.00

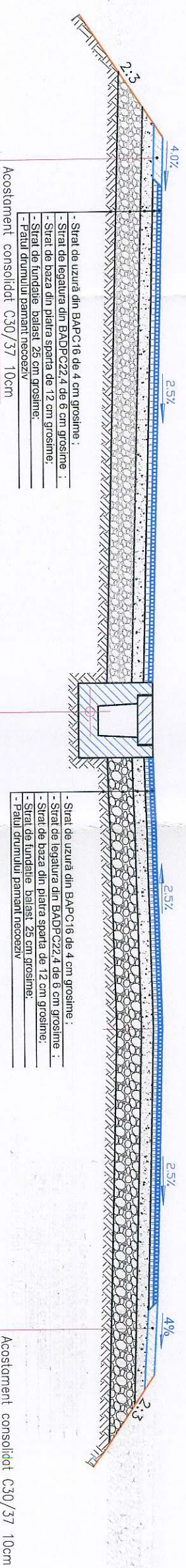

PROFIL TRANSVERSAL TIP 4  
Se aplica pe tronson 2 de la Km 0+000.00 - Km 0+086.00

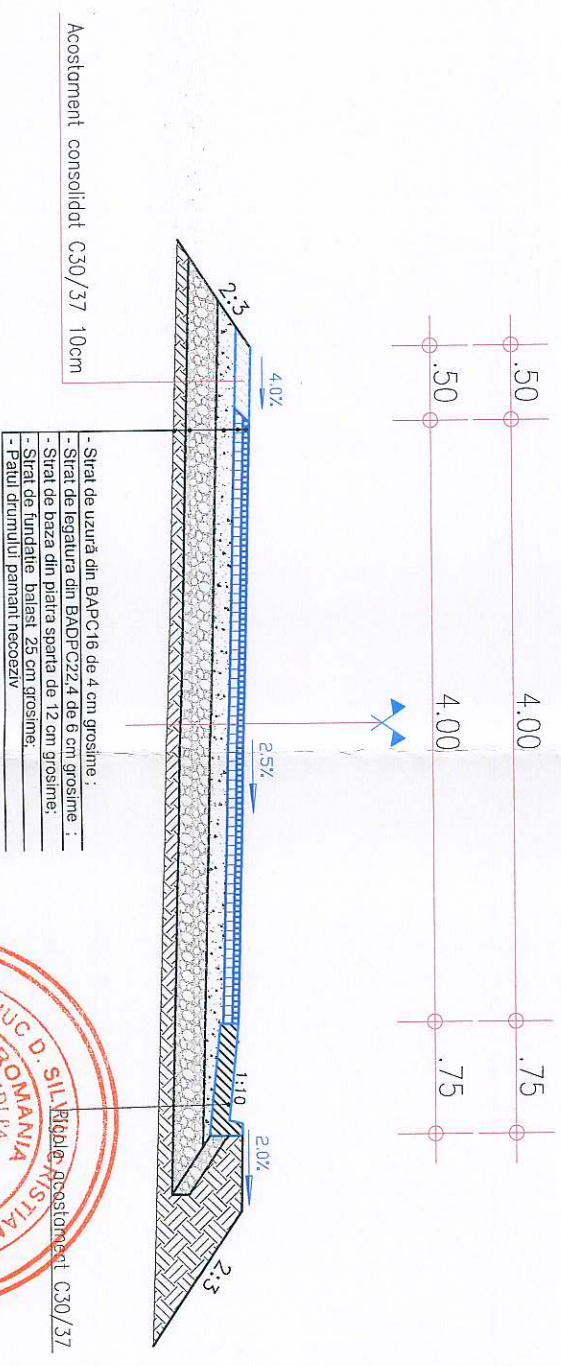

VERIFICATOR NUME:	NUME:	REFERAT NR...../DATA:.....
<p><b>S.C. ULTRA PROJECT S.R.L.</b> BACAU BACAU</p>		
<p>Sat Magura, Comuna Magura, Judetul Bacau J04/632/2008 : C.U.I.-RO 23886508 Tel/fax : 0742 351456 : 0334.107.749;</p>		
SPECIFICATIE	NUME	SEMINATURA
SEF PROIECT	Ing. Dragos Contoman	<i>Dragos Contoman</i>
DISENAT	Ing. Dragos Contoman	<i>Dragos Contoman</i>
PROIECTAT	Ing. Dragos Contoman	<i>Dragos Contoman</i>
SCARA:		TITLU PROIECT: MODERNIZARE STRADA PIETEI SI STRADA BURDUJENI, SAT ARINI, COMUNA GAICEANA, JUDETLUL BACAU
DATA:		TITLU PLANSA: PROFIL TRANSVERSAL TIP
PROIECT NR		4811/2024
FAZA:		Planșa P.Th.+ D.E.



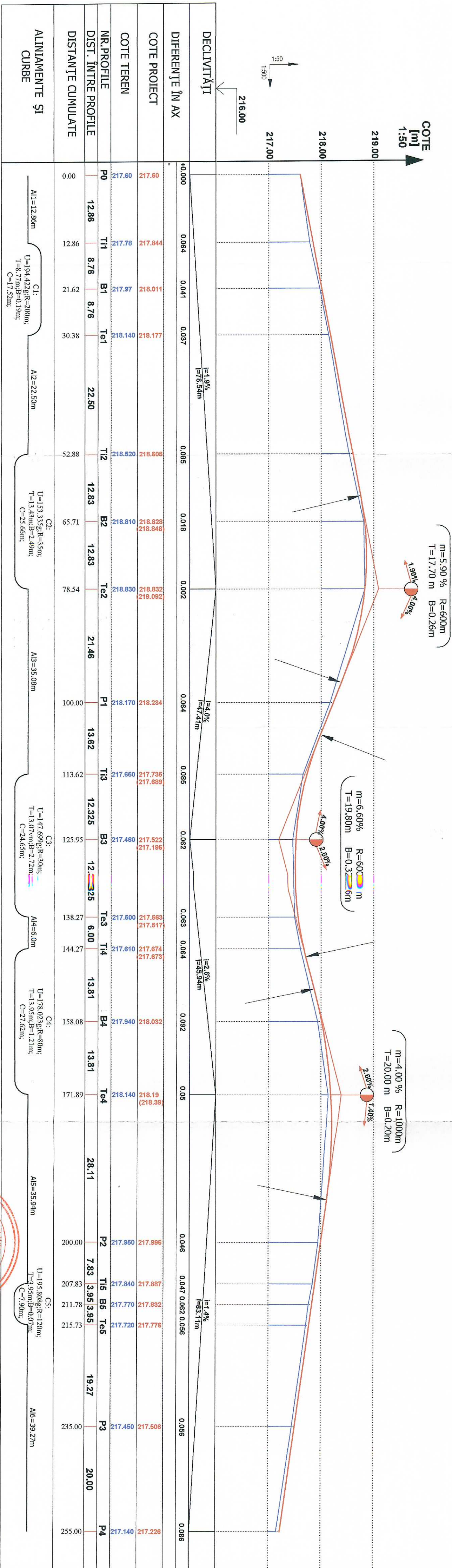

- Legenda**
- Linie teren proiectat
  - Linie teren existent



VERIFICATOR	NUME:	SEMNATURA	CERINTA	REFERAT NR. .... / DATA: .....
S.C. <b>ULTRA PROIECT SRL</b>				
Sat Magura, Comuna Magura, Judetul Bacau				
Județul Bacău				
Tel/Fax: 0742 351456; 0334.107.749;				
SPECIFICATIE	NUME	SEMNATURA	SCARA:	Titlu proiect: MODERNIZARE STRADA PIETELI SI STRADA BURDULIENI,
SER PROIECT	Ing. Dragoș Contoman		1:500; 1:50	SAT ARINI, COMUNA GAICEANA, JUDEȚUL BACĂU
DISPUSAT	Ing. Dragoș Contoman		Data:	PROFIL LONGITUDINAL TRONSON 1
PROIECTAT	Ing. Dragoș Contoman		03/2024	
PROIECT NR	481/2024			
Faza:	P.TI.+ D.E.			

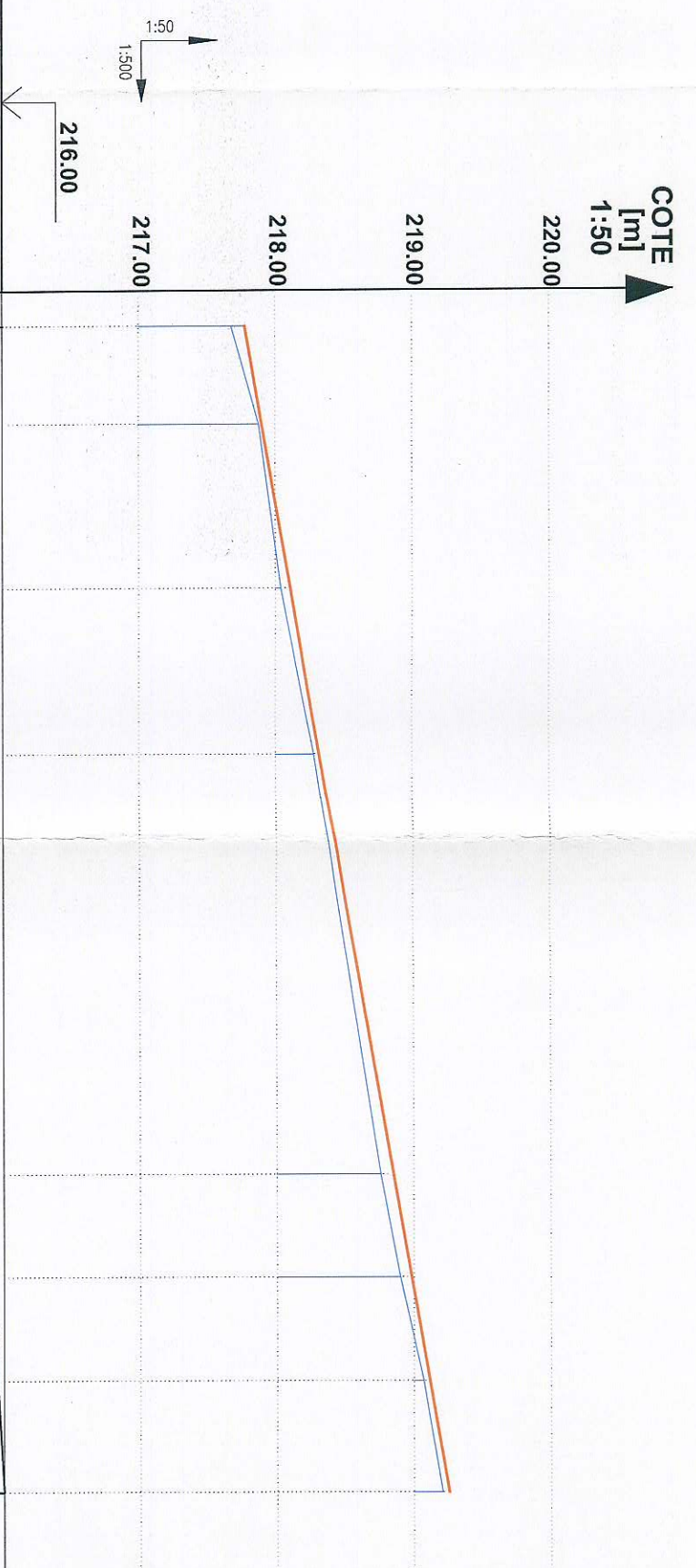

DECLIVITĂȚI	+0.09	0.014	0.064	0.034	0.092	0.083	0.045	0.048
DIFERENȚE ÎN AX								
COTE PROIECT	217.77	217.894	218.104	218.314	218.852	218.983	219.115	219.258
COTE TEREN	217.68	217.88	218.04	218.28	218.76	218.90	219.07	219.21
NR. PROFILE	P0	T11	B1	Te1	T12	B2	Te2	P1
DIST. ÎNTRE PROFILE	7.10	11.995	11.995	31.09	7.525	7.525	8.12	
DISTANȚE CUMULATE	0.00	7.10	19.095	31.09	61.83	69.335	76.88	85.00
ALINIAMENTE ȘI CURBE	AL1=7.10m CI: U=180.911m; R=80m; T=12.08m; B=0.91m; C=23.99m; AL2=30.74m C2: U=120.164m; R=12m; T=8.69m; B=2.82m; C=15.05m; AL3=8.12m							

- Clasa de importanță a lucrării conf. HG. 261/94 este C - lucrări de importanță normală
- Cerința de calitate conf. HG. 925/95 este corespunzătoare capitolului:
- A 4.1 - asigurarea rezistenței și stabilității la sollicitări statice și dinamice
- B 2.1 - siguranța în exploatare a construcțiilor
- D 2 - sanatare și protecția mediului

**Legenda**

— Linie teren proiectat

— Linie teren existent

**DETALIU SISTEM RUTIER PROPUS**



4 cm strat de uzură din BAPC16  
 6 cm strat de legătură BAPC22.4  
 12 cm strat de fundal superior din piatră spartă  
 25 cm strat de fundal balast  
 patul drumului pământ necesoziv

VERIFICATOR	NUME:	NR. SEMNATURA	CERINȚA	REFERAT NR. .... / DATA: .....
SPECIFICATIE	NUME:	SEMNATURA	SCARA:	TITLU PROIECT: MODERNIZARE STRADA PIETEI SI STRADA BURDUJENI, SAT ARINI, COMUNA GAICEANA, JUDETUL BACAU
SEF PROIECT	ING. Dragos Contoman	SEF PROIECT	ING. Dragos Contoman	PROIECT NR. 481/2024
DESEINAT	ING. Dragos Contoman	DESEINAT	ING. Dragos Contoman	HAZAR: P.T.H.+ D.E.
PROIECTAT	ING. Dragos Contoman	PROIECTAT	ING. Dragos Contoman	PROIECT NR. 481/2024
				PLANSĂ D6

**S.C. ULTRA PROIECT S.R.L.**  
 BACĂU

Sat Magura, Comuna Magura, Județul Bacău  
 J04/632/2008 ; C.U.I. RO 23585508  
 Tel/Fax: 0742 351456 ; 0334.107.749





Cote [m]  
Scala 1:100

### PROFIL TRANSVERSAL T11 km 0+012.86

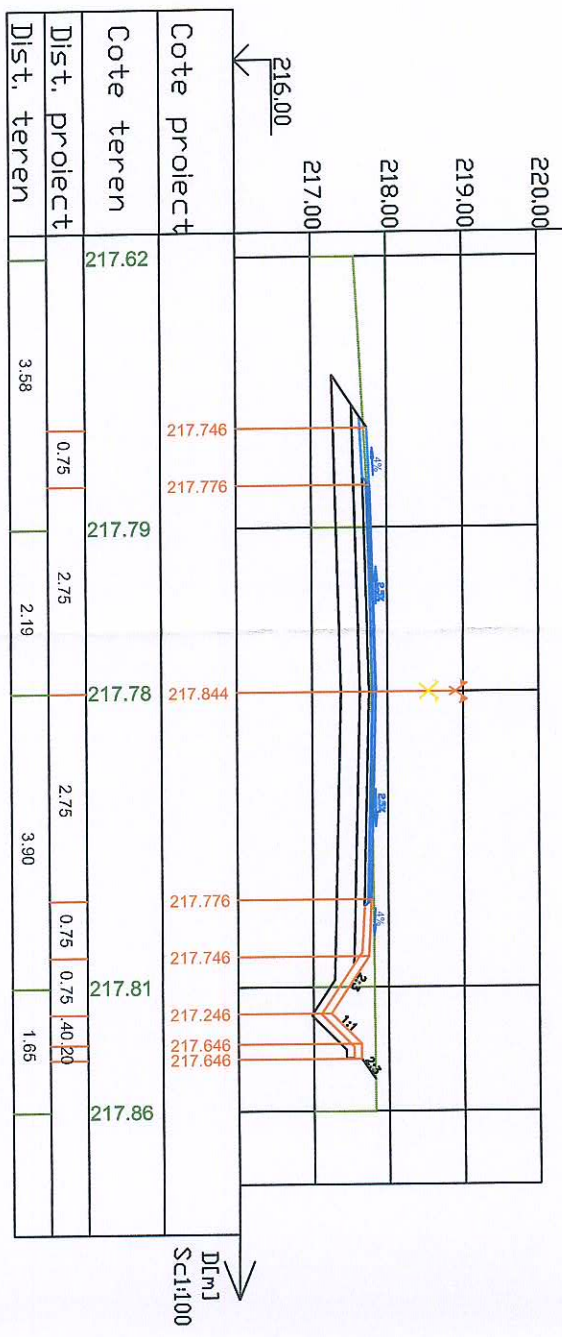

Cote [m]  
Scala 1:100

### PROFIL TRANSVERSAL T2 km 0+078.54

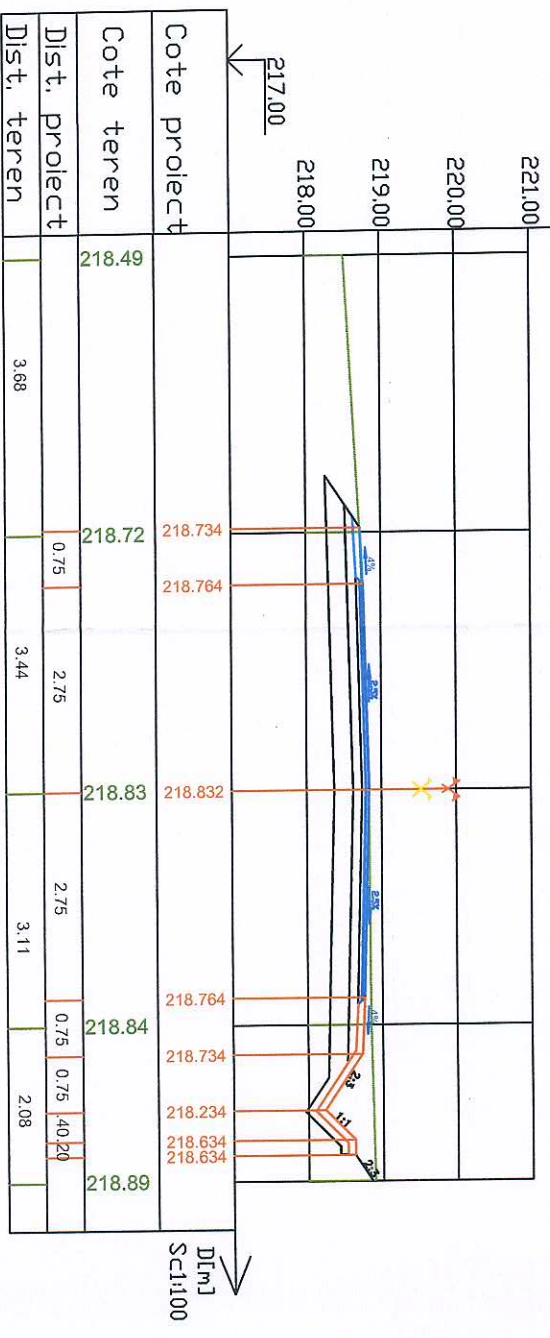

Cote [m]  
Scala 1:100

### PROFIL TRANSVERSAL T12 km 0+052.88

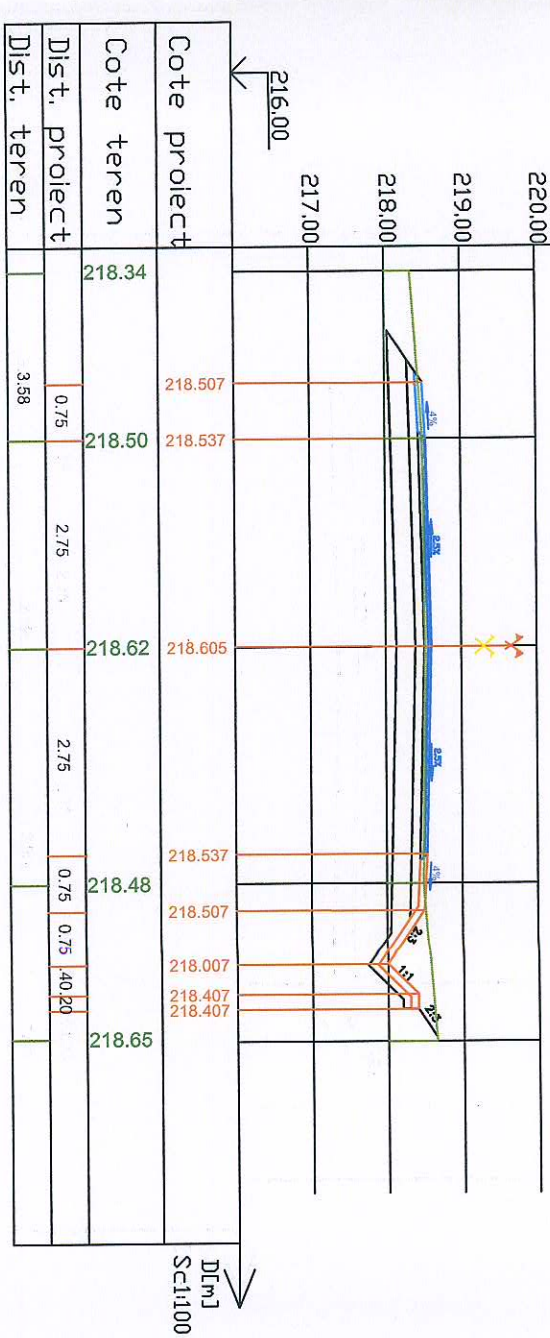

Cote [m]  
Scala 1:100

### PROFIL TRANSVERSAL P1 km 0+100.00

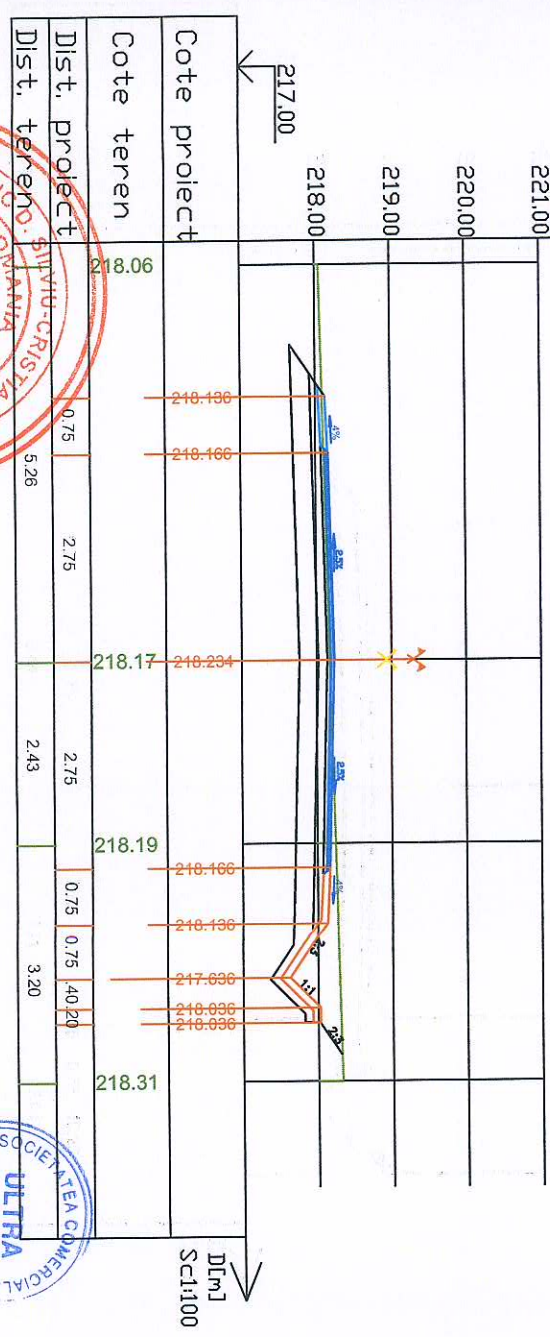

VERIFICATOR NUME: <b>IRICIU ROMULPA</b>	SEMNATURĂ CERINTĂ	REFERAT NR...../DATA:.....	PROIECT NR 481/2024
<b>S.C. ULTRA PROJECT S.R.L.</b> SATELITAR BACĂU		BENEFICIAR: COMUNA GAICEANA AMPLASAMENT: COMUNA GAICEANA, JUDEȚUL BACĂU	FAZA: P.Th.+ D.E.
Sate Magura, Comuna Magura, Judetul Bacau J04632/2008 ; C.U.I. RO 23585508 Tel/Fax : 0742 351456 ; 0334, 107, 749;		Titlu proiect: MODERNIZARE STRADA PIETEI SI STRADA BURDUJENI, SAT ARINI, COMUNA GAICEANA, JUDEȚUL BACĂU	PLANSA D7
SPECIFICATIE NIVNE SEF PROIECT Ing. Dragoș Contoman DESENAT Ing. Dragoș Contoman PROIECTAT Ing. Dragoș Contoman	SEMNATURĂ Data: 03/2024	Titlu planșa: PROFILUL TRANSVERSAL TRONSON 1	

Cote [m]  
Scala 1:100

## PROFIL TRANSVERSAL T11 km 0+090

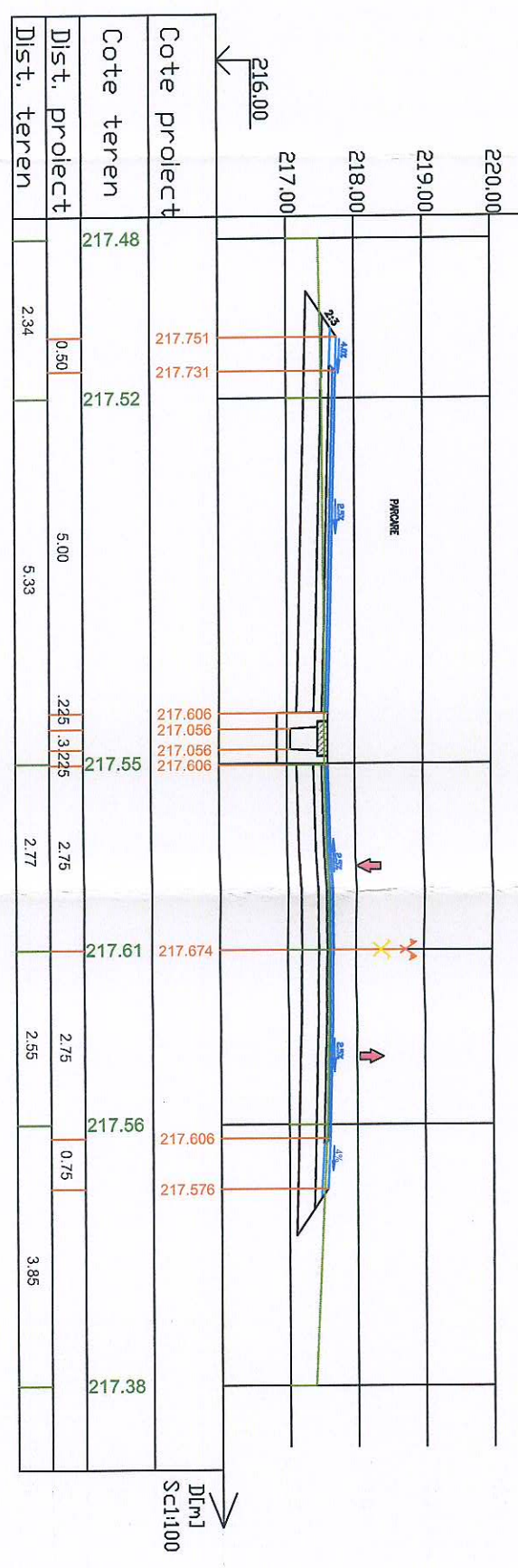

Cote [m]  
Scala 1:100

## PROFIL TRANSVERSAL T11 km 0+090

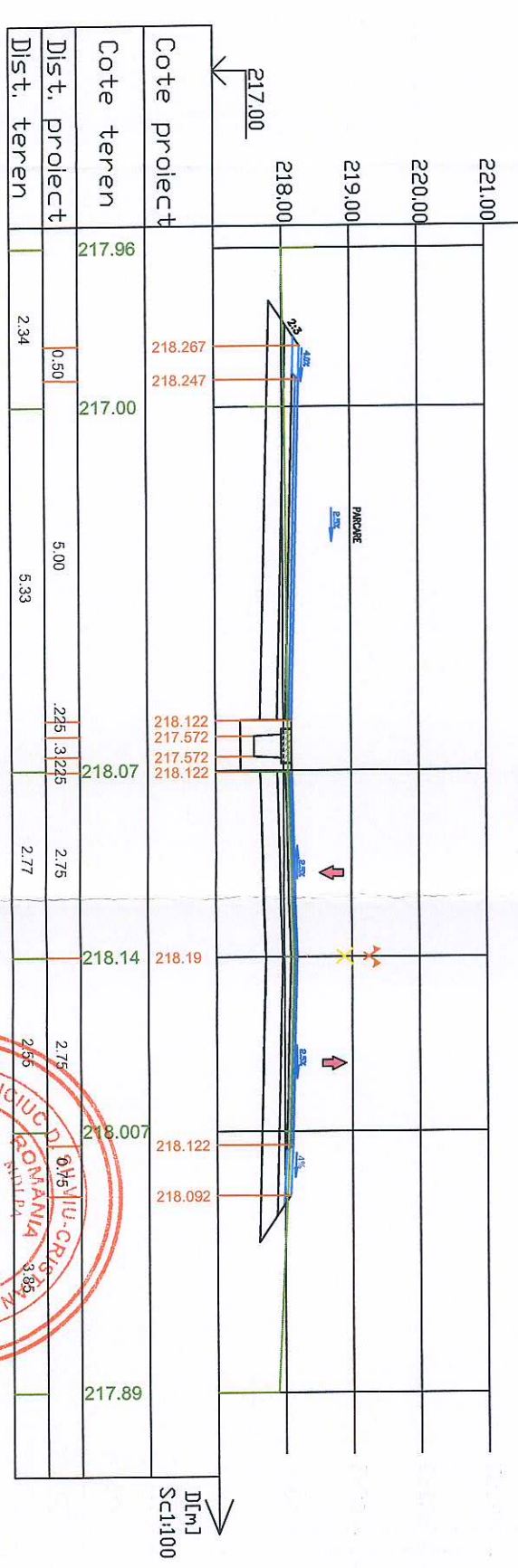

VERIFICATOR NUME:	SEMNATURA CERINTA	REFERAT NR...../ DATA:.....	PROIECT NR: 4811/2024
<p align="center">   <b>SC. ULTRA PROIECT S.R.L.</b>  <b>BACAU</b> </p>		BENEFICIAR: COMUNA GAICEANA AMP/LASAMENT: COMUNA GAICEANA, JUDETUL BACAU	Faza: P.TI.+ D.E.
Sat Magura, Comuna Magura, Judetul Bacau J04/632/2008 : C.U.I. RO 23585508 Tel/fax : 0742 361456 ; 0334.107.749;		Titlu proiect: MODERNIZARE STRADA PIETEI SI STRADA BURDUJENI, SAT ARINI, COMUNA GAICEANA, JUDETUL BACAU	PROIECT NR: 4811/2024
SPECIFICATIE NUME:	SEMNATURA	Scara:	Planșa
SIE PROIECT	Ing. Dragos Contoman	1:100	D8
DESENAT	Ing. Dragos Contoman	Data:	
PROIECTAT	Ing. Dragos Contoman	03/2024	



Cote [m]  
Scala: 1:100

## PROFIL TRANSVERSAL T+5 km 0+207.03

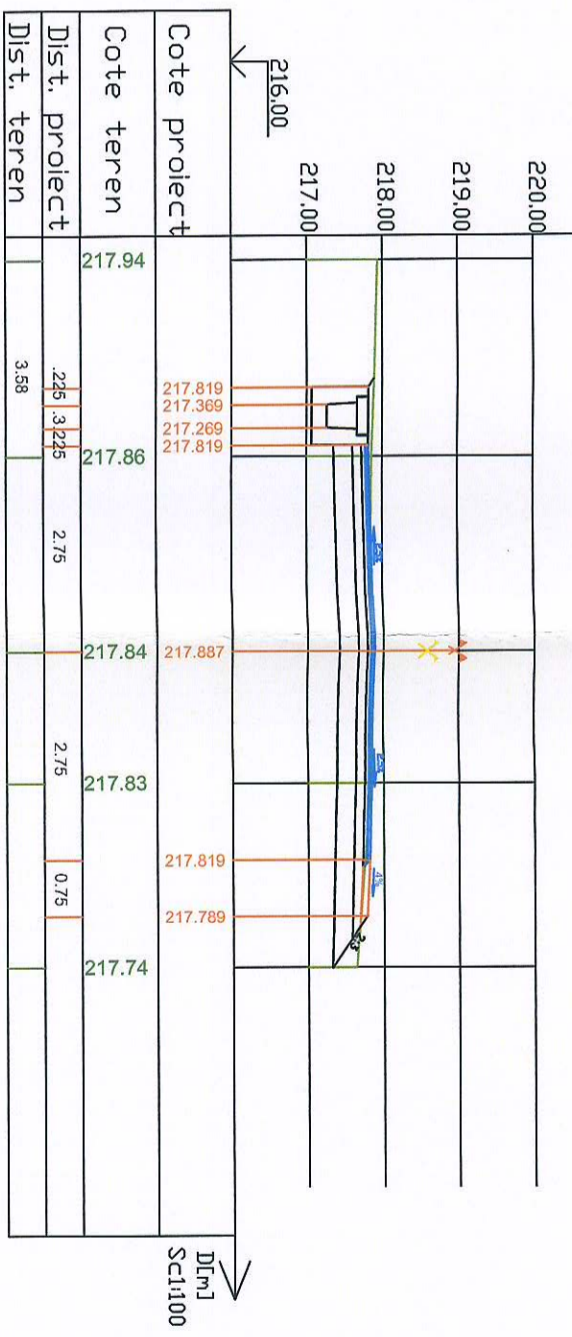

Cote [m]  
Scala: 1:100

## PROFIL TRANSVERSAL P3 km 0+335.00

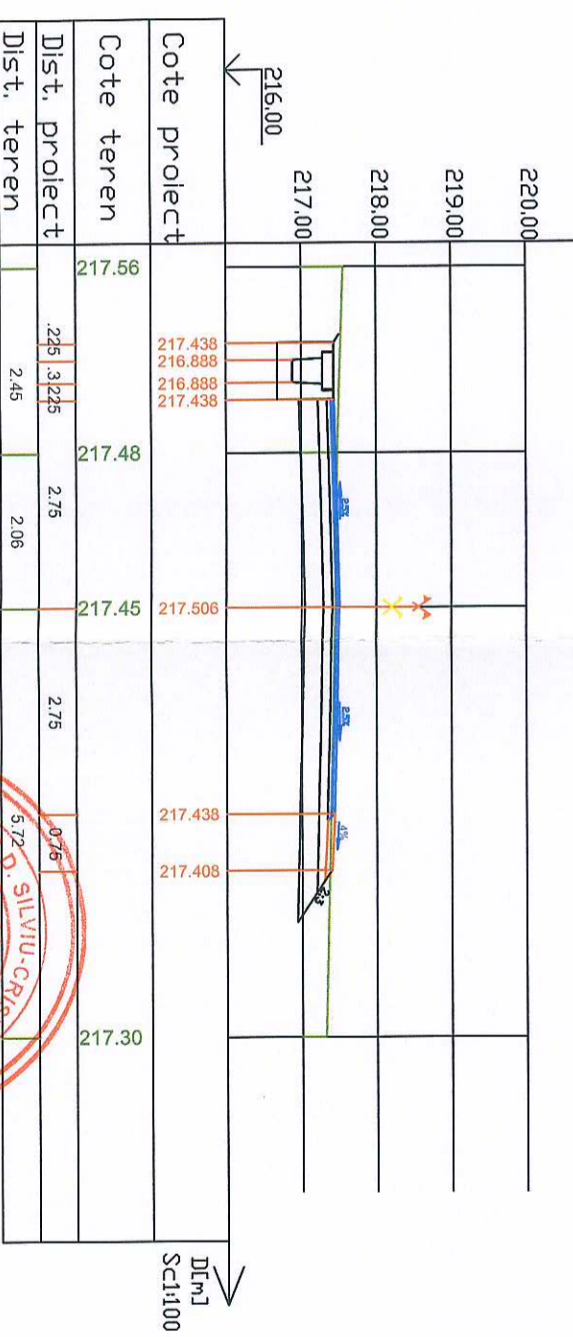

VERIFICATOR NUME: <b>NR. 0218</b>	SEMNTATURA CERINTA	REFERAT NR..... / DATA:.....	PROJECT NR: 481/2024
<p><b>S.C. ULTRA PROJECT S.R.L.</b> BACAU</p> <p>Sat Magura, Satuna Magura, Județul Bacau J04632/2008 ; C.U.I. RO 23565508 Tel/Fax : 0742 351456 ; 0334.107.749;</p>		<p>BENEFICIAR: COMUNA GAICEANA AMPLASAMENT: COMUNA GAICEANA, JUDETUL BACAU</p>	<p>Faza: P.T.H.+ D.E.</p>
<p>SPECIFICATIE NUME</p> <p>SER PROIECT</p> <p>DISENAT</p> <p>PROIECTAT</p>	<p>NUME</p> <p>ING. Dragos Contoman</p> <p>ING. Dragos Contoman</p> <p>ING. Dragos Contoman</p>	<p>SEMNTATURA</p> <p>DATA:</p> <p>03/2024</p>	<p>Titlu proiect: MODERNIZARE STRADA PIETEI SI STRADA BURDUJENI, SAT ARINI, COMUNA GAICEANA, JUDETUL BACAU</p> <p>Titlu plansa: PROFILE TRANSVERSALE TRONSON 1</p> <p>Planşa D9</p>



**PROFIL TRANSVERSAL**  
Te1 km 0+031.09

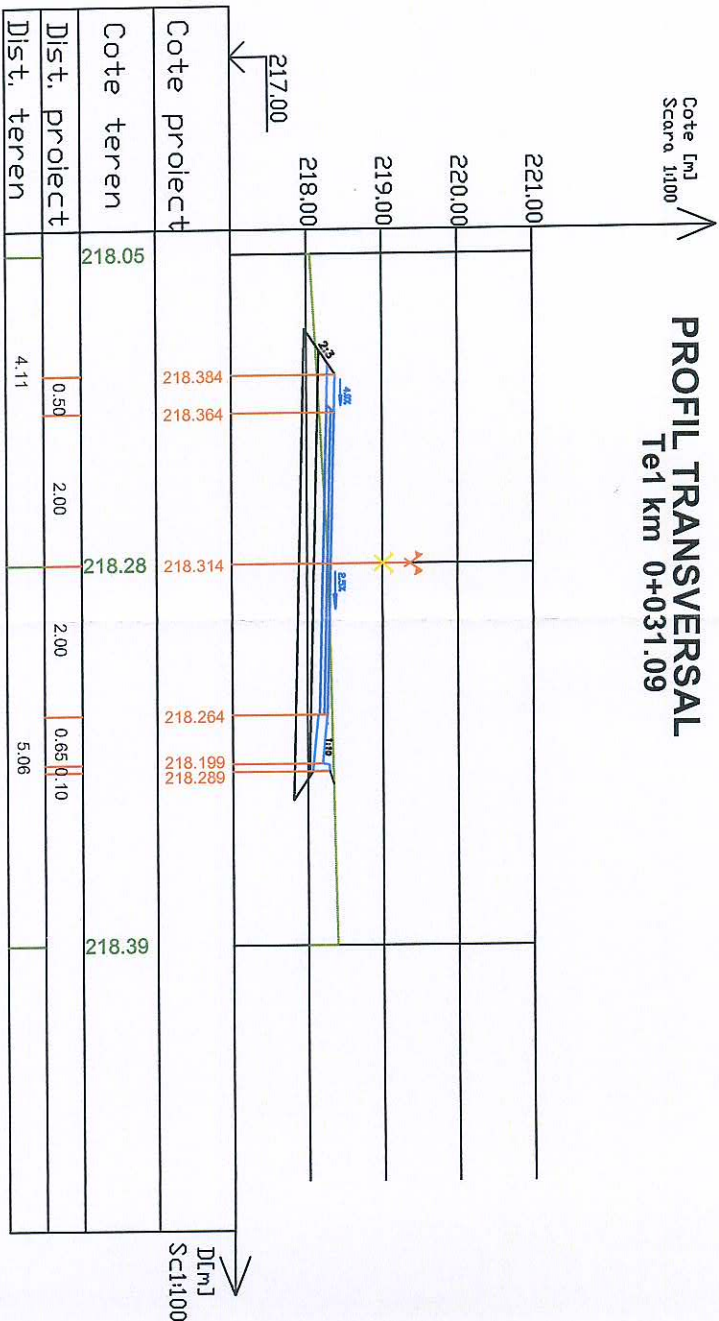

**PROFIL TRANSVERSAL**  
Te2 km 0+076.88

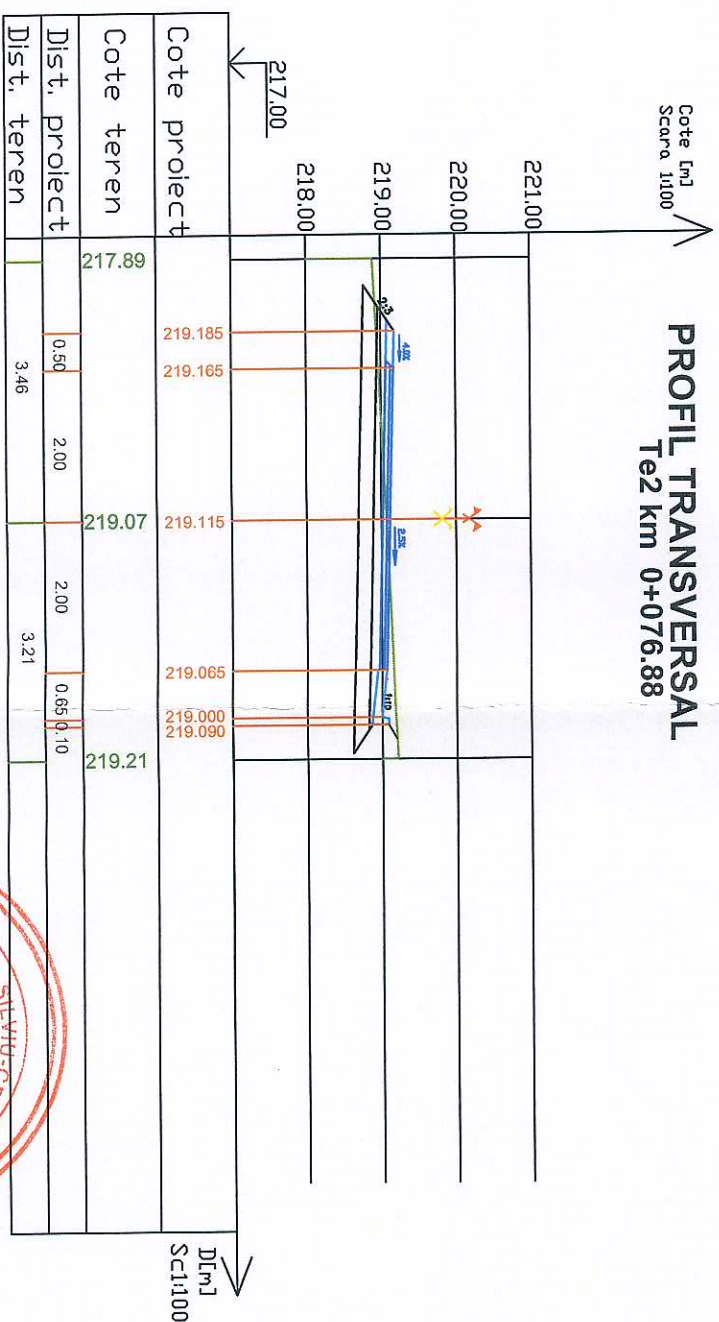

**PROFIL TRANSVERSAL**  
T12 km 0+061.83

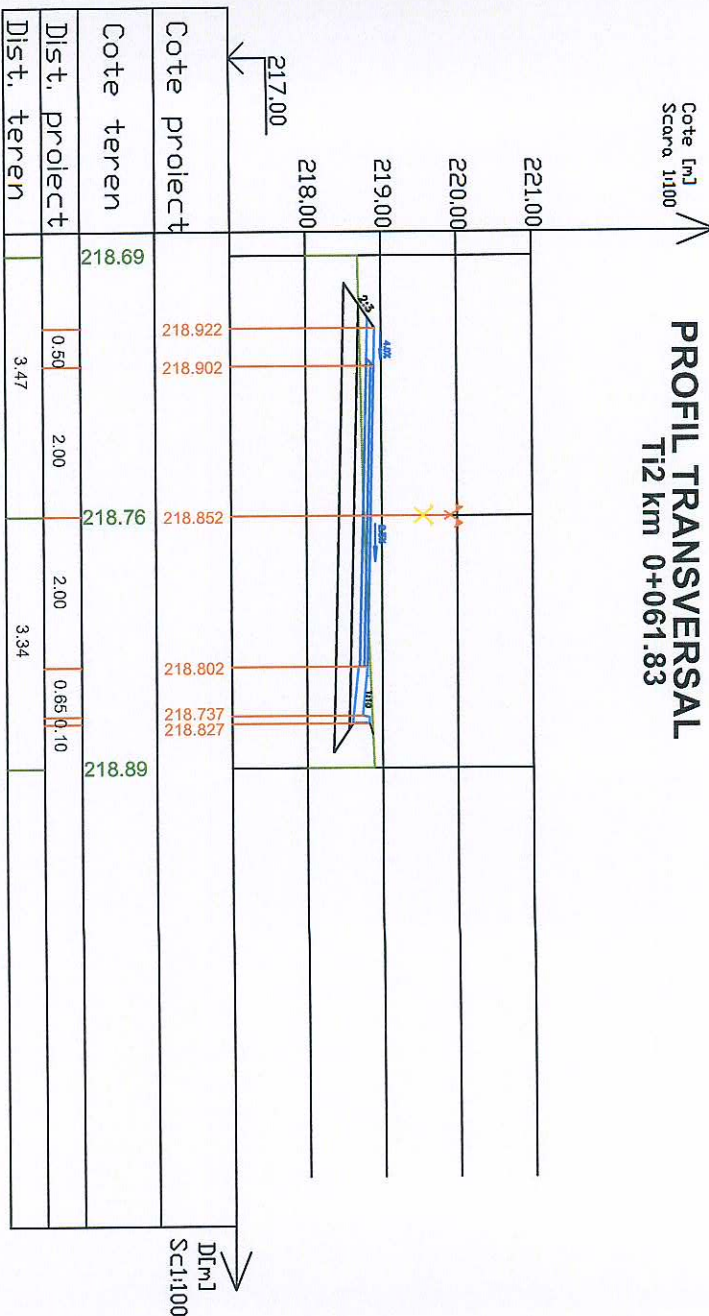

VERIFICATOR NUME:	SEMNATURA CERINTA	REFERAT NR..... / DATA:.....	PROIECT NR 481/2024
<p><b>S.C. ULTRA PROIECT S.R.L.</b> BACAU</p> <p>Sat Magura, Comuna Magura, Judetul Bacau J04/632/2008 - C.U.I. RO.28385508 Tel/Fax : 0742 351496 - 0334.107.749</p>		BENEFICIAR: COMUNA GAICEANA AMPLASAMENT: COMUNA GAICEANA, JUDETUL BACAU	Faza: P.Th.+ D.E.
SPECIFICATIE	NUME	SEMNATURA	Scara:
SER PROIECT	Ing. Dragos Contoman	Dragos	1:100
DISENAT	Ing. Dragos Contoman	Dragos	Data:
PROIECTAT	Ing. Dragos Contoman	Dragos	03/2024
Titlu proiect: MODERNIZARE STRADA PIETEI SI STRADA BURDUJENI, SAT ARINI, COMUNA GAICEANA, JUDETUL BACAU			Planşa D10
Titlu plansa: PROFILE TRANSVERSALE TRONSON 2			



# RIGOLA de ACOSTAMENT

Scara 1:10

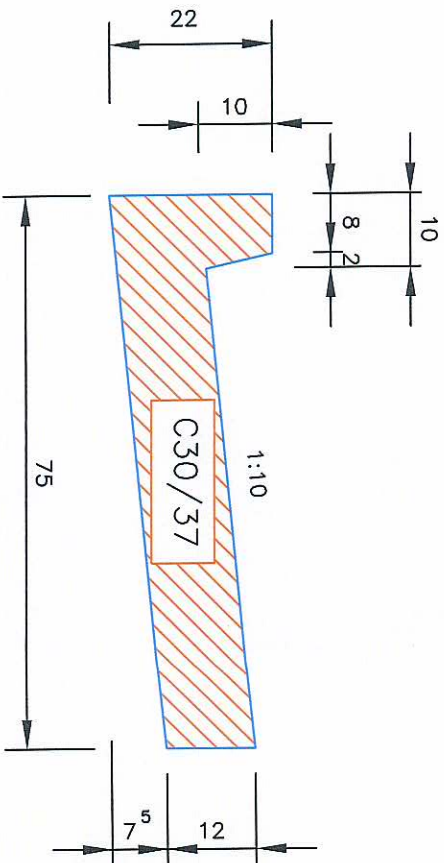

EXTRAS DE MATERIALE PENTRU 1ml. RIGOLA  
hr=10cm

TIPUL RIGOLEI	Pietris	Nisip	Ciment	Elemente prefabricate
	7-31	0-7		
Elemente prefabricate	mc	mc	to	to
	0.061	0.114	0.033	0.22

CARACTERISTICI TEHNICE  
Volum : 0.05 mc  
Greutate : 110 kg  
Latime/ : 0.75 m



VERIFICATOR NUME: <b>NR 10211</b>	SEMNATURAGERINTIA	REFERAT NR...../ DATA:.....	PROIECT NR. 4811/2024	
<b>S.C. ULTRA PROIECT S.R.L. BACAU</b>		BENEFICIAR: COMUNA GAICEANA AMPLASAMENT: COMUNA GAICEANA, JUDETUL BACAU	Faza: P.Th.+ D.E.	
Sat Magura, Comuna Magura, Judetul Bacau J04/632/2008 C.U.I. RO 23585508 Tel/Fax :0742 351456 ; 0334.107.749;				
SPECIFICATIE NUME	SEMNATURURA	Scara:	Titlu proiect: MODERNIZARE STRADA PIETEI SI STRADA BURDUJENI, SAT ARINI, COMUNA GAICEANA, JUDETUL BACAU	Planșa D11
SEPT PROIECT Ing. Dragos Contoman	<i>Dragos</i>	1:10	Titlu plansa: DETALIU RIGOLA DE ACOSTAMENT	
DESINAT Ing. Dragos Contoman	<i>Dragos</i>	Data: 02/2024		
PROIECTAT Ing. Dragos Contoman	<i>Dragos</i>			

**PLACUTA CAROSABILA TIP 2**

**PLACUTA CAROSABILA TIP 1**

**SCARA 1:20**

Se aplica in dreptul drumurilor laterale  
sc. 1:10

sc. 1:10

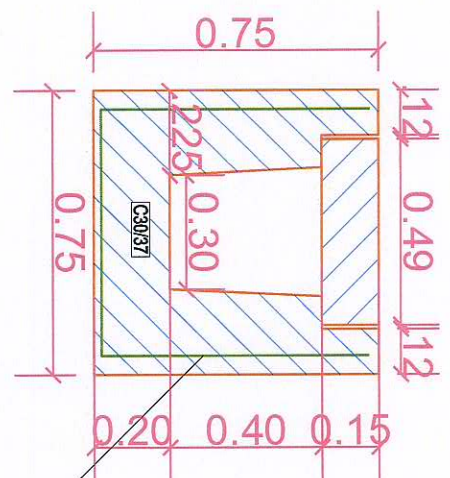
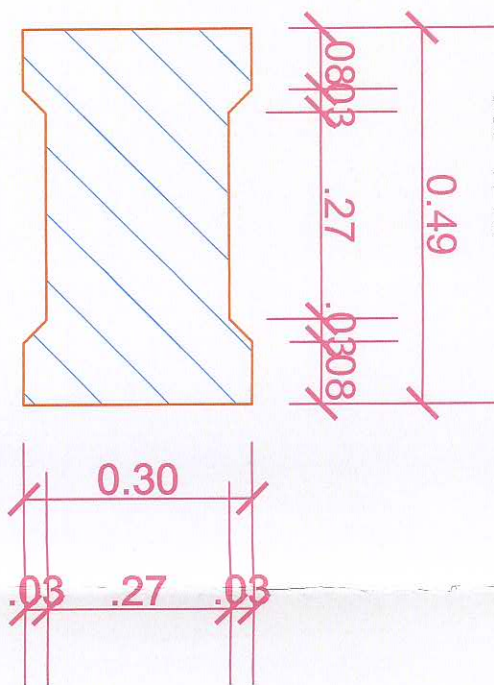
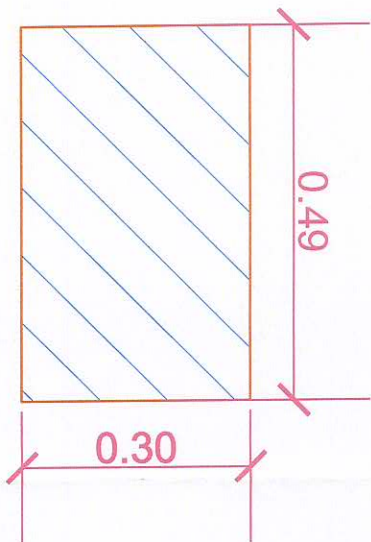

Plasa sudata OB37  $\phi$ 6mm,  
ochiuri de 10x10cm

SECTIUNE A-A

SECTIUNE A-A

SECTIUNE C-C

**EXTRAS ARMATURA PENTRU TRONSOANE DE 3M**  
Plasa sudata OB37  $\phi$ 6mm, 10x10cm = 28.50kg  
Ancore OB37 4buc. x $\phi$ 16 = 6.5 kg

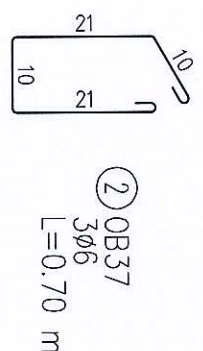
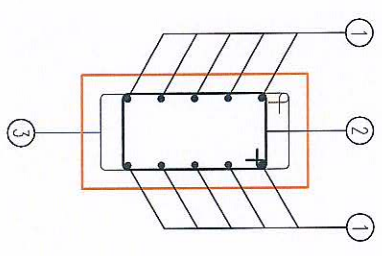
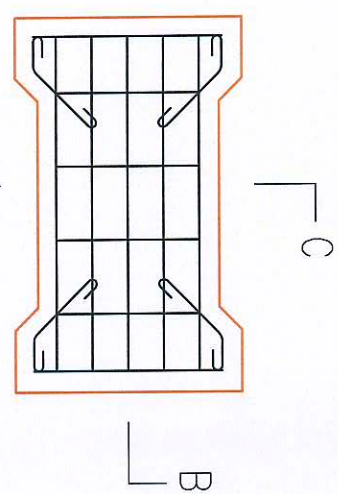
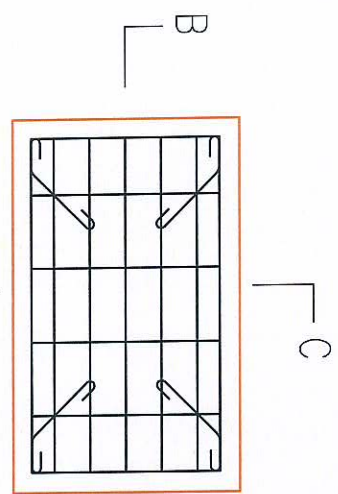

SECTIUNE B-B

SECTIUNE B-B

**EXTRAS PACUTA CAROSABILA**

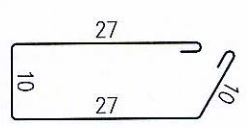
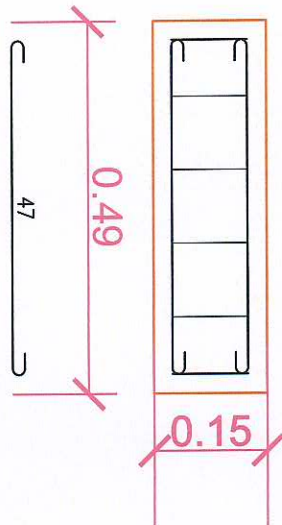
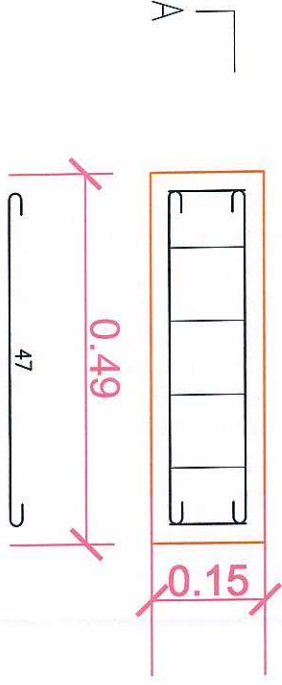

Beton : C30/37  
Otel: OB37  
Volum : 0.0194 mc/buc  
Masa : 46.50 kg/buc  
Armatura : 3.45 kg/buc

① OB37  
2 $\phi$ 8  
L=0.60 m

① OB37  
2 $\phi$ 8  
L=0.60 m

④ OB37  
2x4 $\phi$ 6  
L=0.30 m



VERIFICATOR NUME:	SEMANTURA GERINTA	REFERAT NR...../ DATA:.....
-------------------	-------------------	-----------------------------

S.C. <b>ULTRA PROIECT SRL.</b>		BENEFICIAR: COMUNA GAICEANA
BACAU		AMPLASAMENT: COMUNA GAICEANA, JUDETLUL BACAU

Sat Magurel, Comuna Magurel, Judetul Bacau  
J04/632/2008 ; C.U.I. RO 23585608  
Tel/Fax : 0742 351756 ; 0334 107 749;

SPECIFICATIE	NUME	SEMANTURA	Scara:	Titlu proiect:	PROIECT NR.
SEF PROIECT	Ing. Dragos Contoman	BACAU	1:10; 1:20	MODERNIZARE STRADA PIETEI SI STRADA BURDUENI, SAT ARINI, COMUNA GAICEANA, JUDETLUL BACAU	4811/2024
DRESENAT	Ing. Dragos Contoman	BACAU	Data:	Titlu plansa:	Faza:
PROIECTAT	Ing. Dragos Contoman	BACAU	03/2024	DETALIUL RIGOLA CAROSABILA	P.T.H.+ D.E.
					Planşa D12

# PODET DALAT LA DRUM LATERAL H=0.4m, I=0.5m, L=8.0m

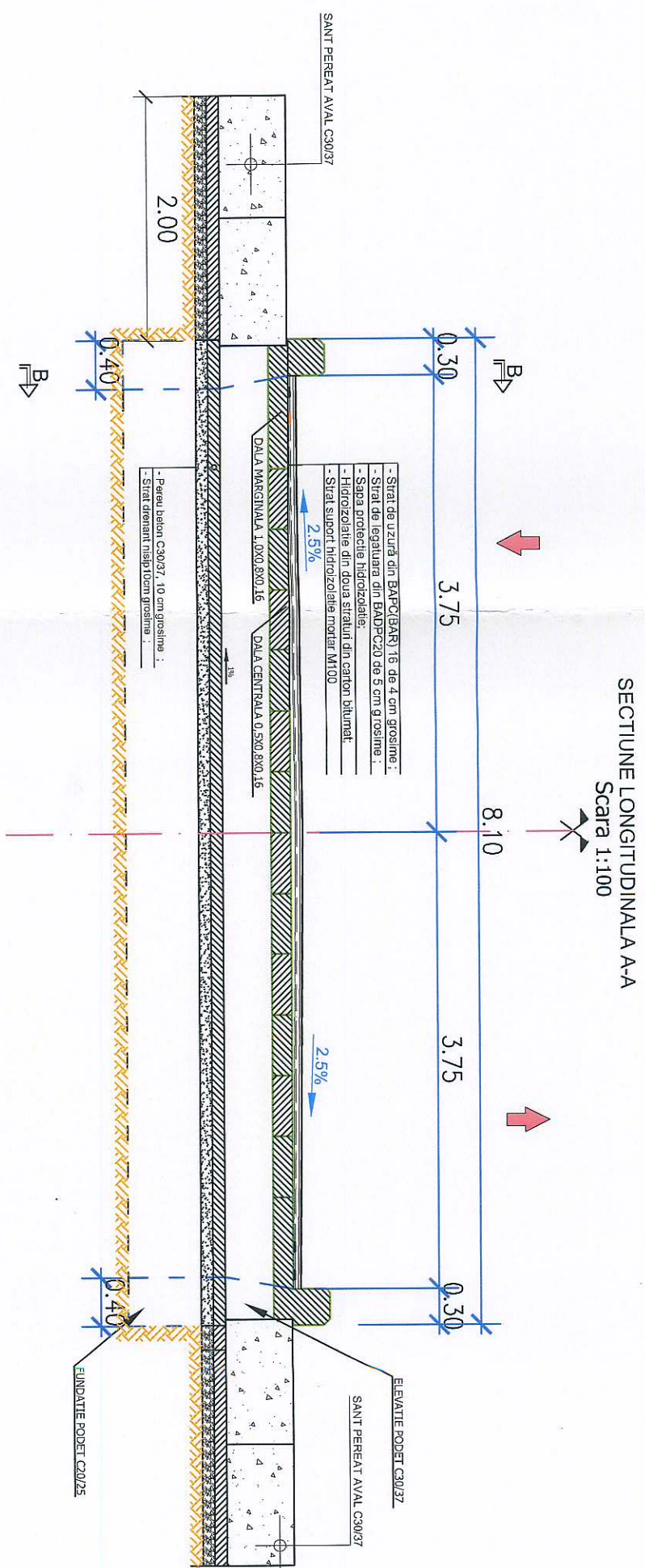
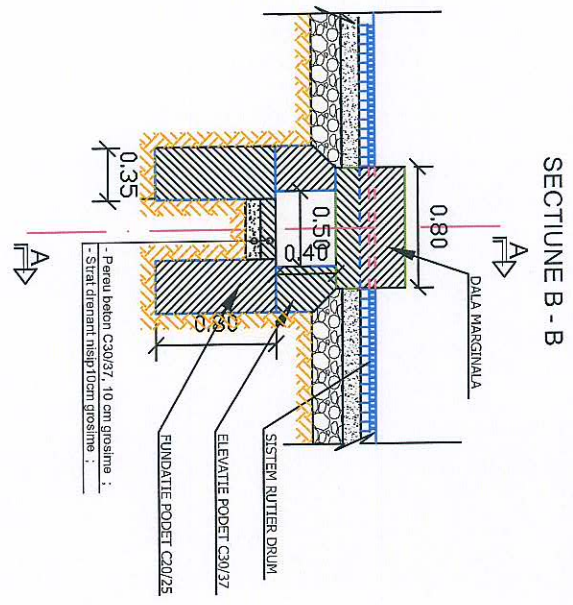

VEDERE IN PLAN  
Scara 1:200

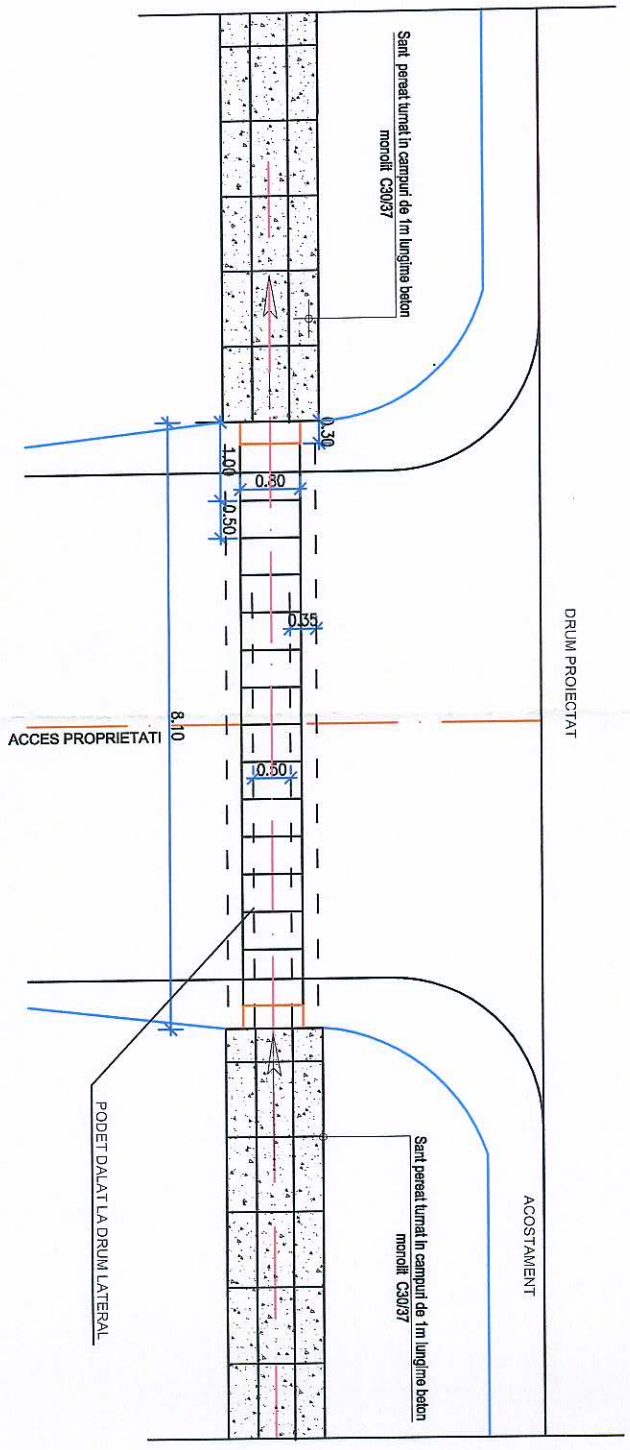

DETALIU D

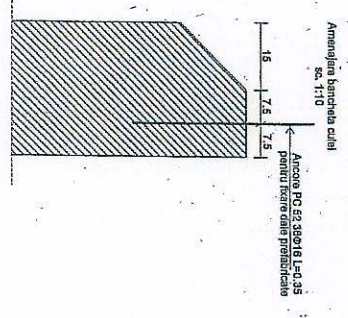

VERIFICATOR NUME:	IRICIUC D. SILVIU-CRISTIAN	SEMNAȚURA CERINȚA	REFERAT NR. .... / DATA: .....
PROIECTANT	ING. DRAGOS CONTOMAN	SEMNAȚURA	PROIECT NR. .... / DATA: .....
DISENINAT	ING. DRAGOS CONTOMAN	SEMNAȚURA	PROIECT NR. .... / DATA: .....
SEF PROIECT	ING. DRAGOS CONTOMAN	SEMNAȚURA	PROIECT NR. .... / DATA: .....
SPECIFICATIE	NUME	SEMNAȚURA	SCARA:
PROIECT	ING. DRAGOS CONTOMAN	SEMNAȚURA	1:20
DISENINAT	ING. DRAGOS CONTOMAN	SEMNAȚURA	DATA:
PROIECTANT	ING. DRAGOS CONTOMAN	SEMNAȚURA	03/2024
S.C. <b>ULTRA PROIECT S.R.L.</b>		BENEFICIAR: COMUNA GAICEANA	
BACAU VERIFICATOR DE PROIECT		AMPLASAMENT: COMUNA GAICEANA, JUDEȚUL BACAU	
Sat Magura, Comuna Magura, Judetul Bacau		TITLU PROIECT: MODERNIZARE STRADA PIETEI SI STRADA BURDUJENI, SAT ARINI, COMUNA GAICEANA, JUDEȚUL BACAU	
J04/632/2008 ; C.U.I. RO-23355508		PODET DALAT LA DRUM LATERAL	
Tel/fax : 0742 351456 ; 0334.107.749		H=0.4m, I=0.5m, L= 8.0m	
Faza: P.TI.+ D.E.		PROIECT NR. 481/2024	
SOCIETATEA COMERCIALA <b>ULTRA PROIECT S.R.L.</b>		Faza: P.TI.+ D.E.	
BACAU		PROIECT NR. 481/2024	
SOCIETATEA COMERCIALA <b>ULTRA PROIECT S.R.L.</b>		Faza: P.TI.+ D.E.	
BACAU		PROIECT NR. 481/2024	

